

Specifications

Luxury - Elegance - Durability

The frame is constructed from hollow steel sections and designed in accordance with AS1170-1981, AS1250-1981 to withstand wind loading of 0.5kPa in the closed position and provide minimum deflection in the open position.

Applications - Suitable where minimal internal projection is required. This door is not recommended for high wind applications.

Operation - Two leaf hinged horizontally, counterbalanced with counterweights under constant suspension. Door movement is controlled by guide roller operating in 60 x 70 x 60 x 3m guide channels.

Size

Maximum height: 6,000mm
Maximum width: 10,000mm

Cladding (Steel) - Doors can be clad with various sheeting materials. Standard Colorbond profiles are commonly used however specialized profiles can be used. Please consult the manufacturer on the use of non standard sections.

Cladding (Glass) - Doors can be partially or fully glazed for viewing or showroom display and are glazed in accordance with AS1288. Standard glazing uses 6.38mm laminated safety glass. The use of other glass or glazing material should be referred to the manufacturer due to additional weight, deflection, door design and construction. Glazed doors will generally incorporate a kickplate in the base of the bottom leaf. Door size and weight will determine kickplate height.

Bar Grille - This door is constructed of standard RHS frame covered with 20mm square hollow steel tube welded vertically over the entire door face at approximately 120mm centers.

Other Cladding - Other available cladding commonly used are plywood, mesh, perforated sheet, woven wire & galvanized sheet.

Finishes - Standard finish on frames and channels is epoxy primed and polyurethane. On glazed doors beading can be anodized or powdercoat finish. Other finishes are available if required, please specify.

Locking - By use of internal padbolts unless otherwise specified. Motorized doors will not be fitted with locks.

Counterweight Covers - The counterweights shall be protected and covered with a removable pressed sheet to meet design requirements.



Optional Extras

Escape and Access Doors - Can be incorporated into door design providing bottom leaf height is sufficient. Locking is by a night latch unless otherwise specified. It is recommended that access doors open outward on a Series 2000 door.

Motorization - Operation by a ramp and carriage designed for smooth opening and closing. The carriage is driven by an overhead shaft connected to a three or single phase drive unit incorporating open and close limit switches.

Renlita Overhead Doors has a continuous program of product development and reserves the right to change specifications at any time without notice.

Renlita Overhead Doors

Counterweight Balanced Door

Renlita Series 2000 Counterweight Balanced Door is a contemporary concept offering luxury, elegance and durability.

Designed for industrial / commercial and domestic applications where minimum internal projection is desired, this door requires little headroom.

Allowing natural light in or bringing the outside in, the Renlita Series 2000 door design will compliment the architecture of your home or business.

RENLITA SERIES 2000 HINGEWAY DOORS

Contact Details

Renlita Doors North America, LLC

Mailing Address: P.O. Box B, Bonham, TX 75418
Shipping Address: 220 E First St, Bonham, TX 75418
Phone: 903-583-7500 | Fax: 903-583-7544
Renlita Doors North America, LLC is a licensee of The ARA Group.

Renlita Doors New York City

Metro Area Representative: Susan Oliner, Harrison Leigh, LLC
5 Manor Lane, East Hampton, NY 11937
Phone: 973-477-3886 | Fax: 631-324-3577

Renlita Doors Canada

57 Luella Blvd, Minesing, Ontario L0L 1Y2
Phone: 705-828-0845 | Fax: 705-737-2624

Visit our website: www.renlitadoors.com



Features

- ▶ The Renlita Foldaway Series 2000 counterweight balanced door is designed for industrial/commercial and domestic applications where minimum internal projection is required.
- ▶ Little headroom is necessary for this type of door. The doors accept a wide range of cladding and/or glazing materials and come in many colors to suit your design brief.
- ▶ When opening, the door folds along a horizontal hinge line and moves upward coming to rest immediately below the lintel.
- ▶ Dimensions of the doors vary according to the application and each door is individually designed.
- ▶ Mathematical calculations are completed to ensure the door is correctly counter weight balanced.
- ▶ Wind loading can be a critical design factor especially in cyclone prone areas unless otherwise specified the doors are designed to resist a minimum wind loading of 0.5 kPa.

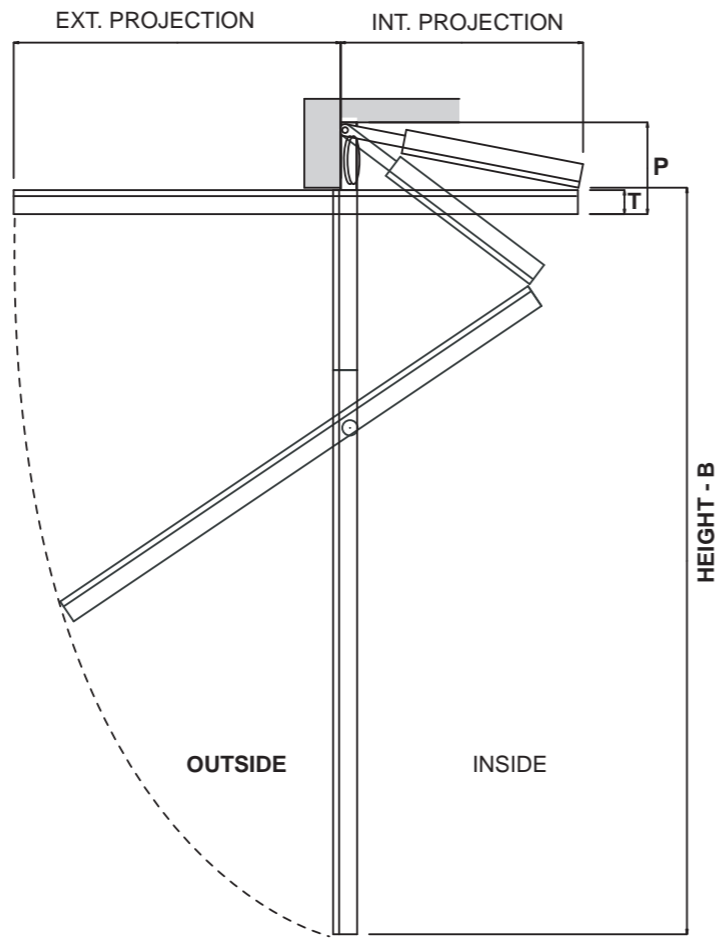

Counterweights each side of single door

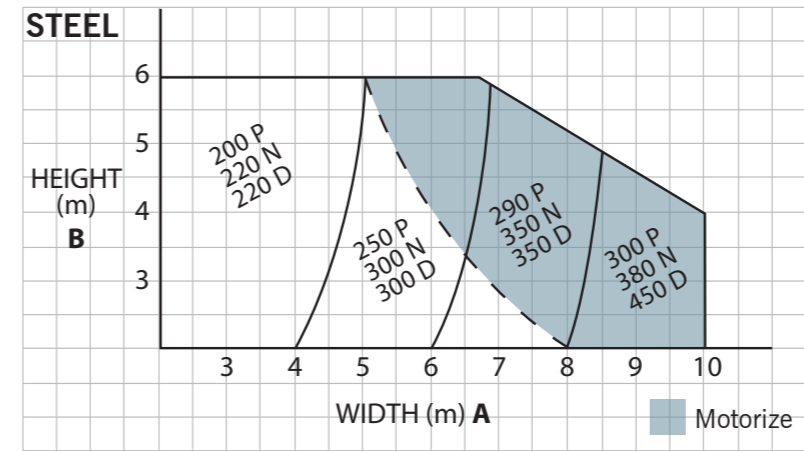

P = Pulley Headroom - min 430 for motorized
 N = Room Width - add 25 for motorized
 D = Room Depth

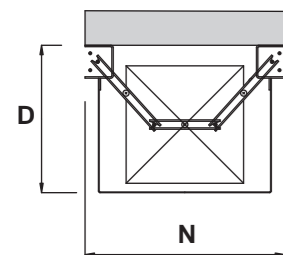
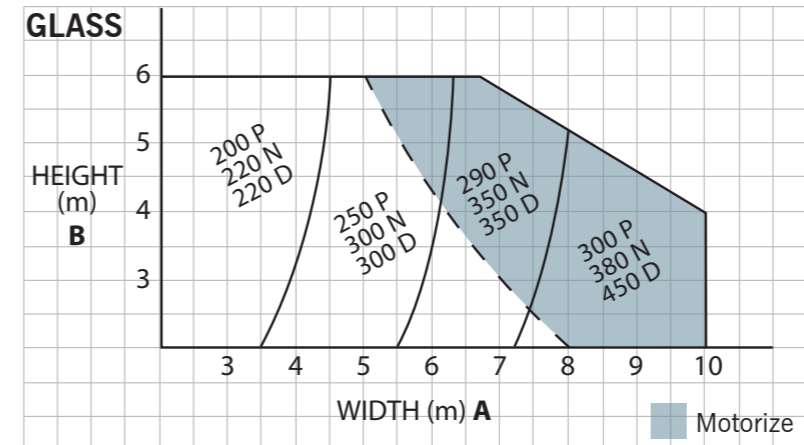

Common column between 2 identical doors

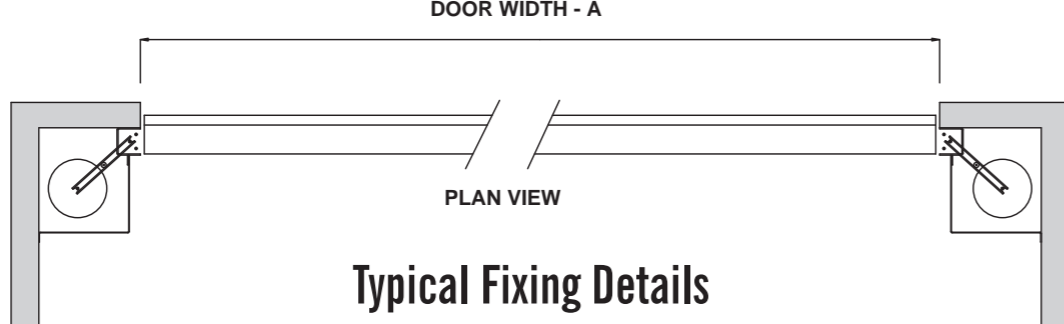

Typical Fixing Details

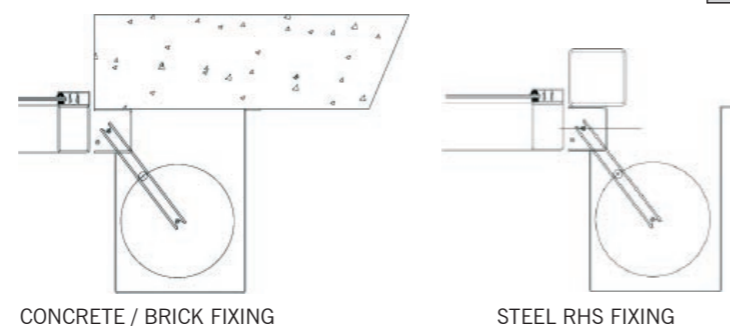

CONCRETE / BRICK FIXING

STEEL RHS FIXING

Counterweights each side single door

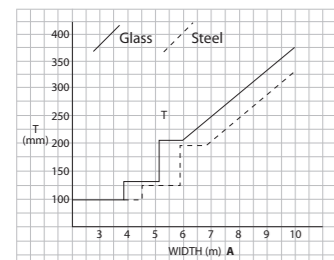
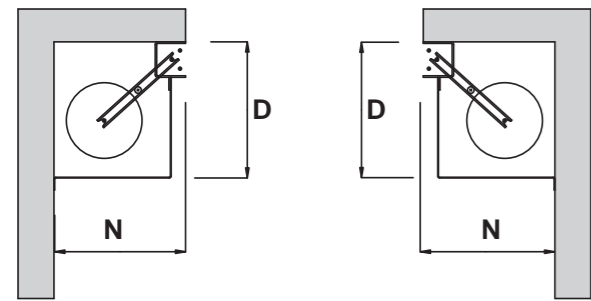

THICKNESS UNDER LINTEL

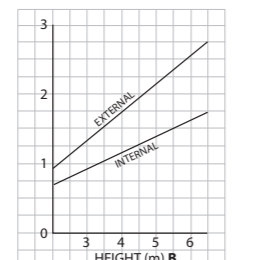

POSITION OF OPEN DOOR

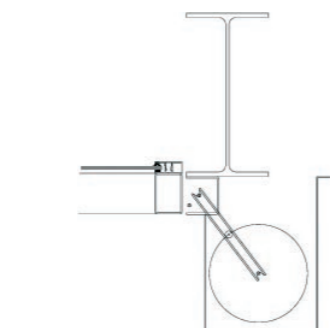

STEEL RSJ FIXING

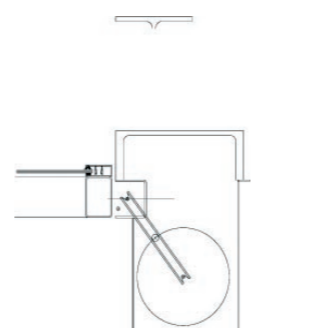

STEEL PFC FIXING



View from inside

Common column between two identical doors

